

Operating instructions

► Read and follow these safety instructions first and take notice of the operating instructions.

- 1.1 The installation, maintenance, initial operation, removal and repair may be done by qualified experts only.
- 1.2 The statutory and other applicable regulations and standards have to be noticed and kept.
- 1.3 The maximum pressure and temperature given by the data plate have to be noticed and kept.
- 1.4 If the valve is damaged the filling pipe has to be shut off and the silo is to relieve from any pressure.
- 1.5 Carry out maintenance and repair work only when the silo or vessel is not in use and no over- or low pressure is present. The valve must be removed and disassembled in pressure-free condition only.



!!! By use of the device in explosive hazardous areas take notice of the following safety instructions.



2. Safety instructions by application in explosive hazardous areas:

- 2.1 The installation, maintenance, initial operation, removed, and repair has to be supervised resp. controlled by an "authorized person" for explosion protection.
- 2.2 The valve is only to use in the categories given by the type plate or lower categories.

Type	Category	usable in	
		inside	ambient
SEI-250-B4	2D	zone 21 or zone 22	zone 21 or zone 22

- 2.3 The valve has to be permanently conductive connected to the conductive earthed silo or vessel. If the silo or vessel is not conductive the valve has to be connected to the compensation of potential of the plant.
- 2.4 The earth cables between valve and frame and between valve and clamping ring and has not to be removed. If a cable is damaged a new conductive connection is to establish by qualified experts.
- 2.5 Depending on the bulk goods characteristics (e.g. abrasion) the operator has to schedule resp. evaluate in what intervals the valve disc has to be tested about abrasion to keep the conductivity and repeat this inspection on a regular base.
- 2.6 Take notice of the requirements of DIN EN 60079-14, DIN EN 60079-17 and DIN EN 1127-1, especially regarding the dust deposits and temperatures and follow the pertinent rules and regulations.
- 2.7 Please note that the device produces no elevation of the temperature by itself, but can transfer high temperatures from inside the vessel to outside or the other way round.
Because of this reason the surface temperature resp. the temperature class has to be defined according to the internal temperature of the vessel or the outside temperature (ambient temperature).



- 2.8 **ATTENTION!**
If the earth cables were loosen or removed for installation, pressure adjustment or maintenance then they have to be mounted conductive connected again before the valve is put into operation.

The Silo-Ex-Impl-Valve protects silos and vessels from high pressure and low pressure.

Dimensions

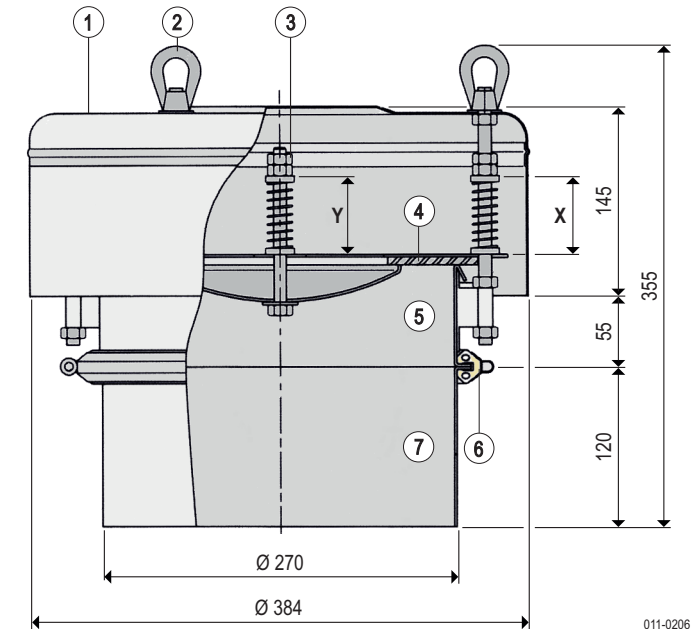

011-0206

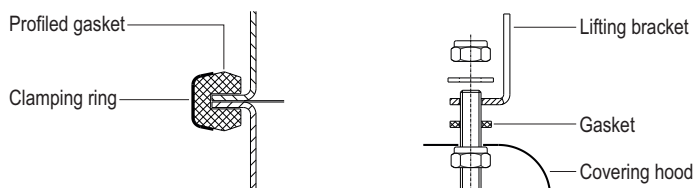

Use

The Silo-Ex-Impl-Valve has been mounted at the top of silos or vessels.

It protects against

- pneumatic filling
- Sticking of the dust precipitation filter
- Fermentation
- Temperature variations
- Condensation
- high output
- Aspiration

Technical data

Type	SEI-250-B4
Materials	<ol style="list-style-type: none"> 1 Covering hood Stainless steel 1.4306 / 304 L 2 Lifting bracket 1.4306 / 304 L 3 Spring guidance, screws and nuts 1.4306 / 304 L 4 Valve disc 1.4306 / 304 L and gasket black, conductive 5 Corpus 1.4306 / 304 L 6 Clamping ring 1.4306 / 304 L and profiled gasket, neopren white, food 7 weld-in frame 1.4306 / 304 L
Installation	vertical (flared-end tube horizontal)
Temperature range	T_a -25 °C ... +70 °C

Curve by overpressure

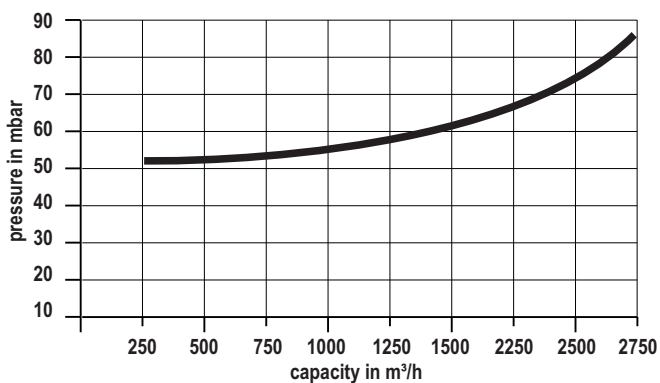

Curve by low pressure

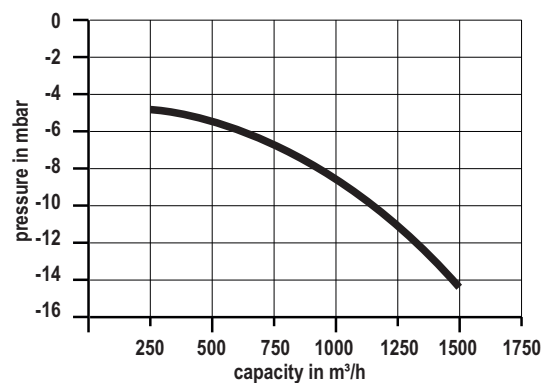

Adjustment tables

High pressure		Low pressure	
X mm	mbar	Y mm	mbar
65	60	50	12
75	50	63	9
85	40	80	5
		92	2

Factory setting

High pressure	50 mbar
Low pressure	2 mbar
max. adjustable pressure	
High pressure	60 mbar
Low pressure	12 mbar

1. Manufacturer data

Manufacturer	MOLLET Füllstandtechnik GmbH
Address	Industriepark RIO 103 74706 Osterburken
Name	Silo-Ex-Implo-Valve
Type	SEI-250-B4

2. Description

2.1 Intended use

The Silo-Ex-Implo-Valve protects silos and vessels against over- and low pressure eg. by pneumatic filling or blockage of vacuum cleaning filter.

2.2 Function

If a over- or low pressure crossed the pre-set value of the valve the valve disc will open. Thereby the pressure will be released and the valve disc is closing again.

3. Installation

3.1 Preparation

- Read and follow the safety instructions and the operating instructions before starting work on the device!
- Take notice of the technical specifications on the data plate.

3.2 Mounting in the vessel and assemblage

- Weld the frame all around and dust-proof in the prepared opening in the roof of the silo or vessel.
- Remove both halves of the clamping ring from the profiled gasket.
- Put the corpus with the profiled gasket at the frame.
- Put the profiled gasket over both flared-end tubes of the frame and the corpus.
- Encircle the profiled gasket with both clamp-ring halves and tighten both screws equally.
- The earth cables between valve and frame and between valve and clamping ring has not to be removed.

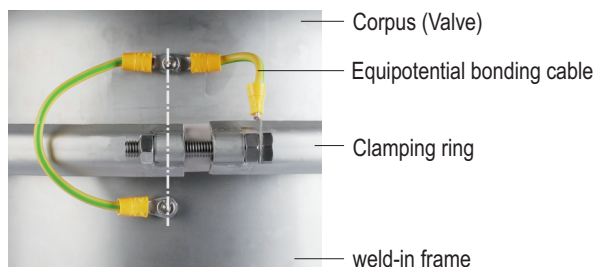

- Put the covering cap of the 3 threaded bolts and fasten it with the attached seal rings, eyelets, washers and nuts.

3.3 Pressure adjustment

The over- and low pressure adjustment can be altered according to the **adjustment tables**.

Proceed as follow:

- Remove the eyelets and take off the covering cap.

Over pressure adjustment

- Loosen the counter nuts of the three external spring guidances and adjust the distance **X** at all springs by turning the nuts.

Low pressure adjustment

- Loosen the counter nut of the central spring guidance and adjust the distance **Y** by turning the nut.
- After the adjustment tighten the counter nuts.
- Place off the covering cap and fasten the lifting brackets.

4. Utilization

4.1 Commissioning

- Commissioning of the high and low pressure valve only when it's mounted correctly.
- Use the valve only with pressure adjustments beneath the pressure limit of the silo or vessel.

4.2 Normal operation

- Use the Silo-Ex-Implo-Valve in its intended application only.
- Follow the data on the type plate.

4.3 Inexpert handling

- Ignoring the safety instructions and operation instructions.
- Not intended use.
- Pressure adjustments above the pressure limit of the silo or vessel.
- Mounting of spare parts which are no original parts.
- Violation against applicable law and standards.

5. Maintenance and servicing

5.1 General informations

- Carry out maintenance and servicing works only when the silo or vessel is not in use and when no over- or low pressure is present.
- If it's reckon with a danger of exhausting damaging substances during the maintenance or repair special protective measures (e.g. personnel protective kits) are necessary.
- Use original spare parts only.

5.2 Maintenance

Inspect in regular intervals:

- all parts of the valve for cleanness,
- seals and springs for damage and wear and tear,
- valve discs for function,
- all screws and nuts for tight fit.

The maintenance interval is depending on the frequency of filling and emptying and also of the kind of bulk goods stored in the silo or vessel.

5.3 Servicing

- Damaged parts have immediately replaced with similar.
- The silo/vessel must not be used until the complete repairing of the valve's proper function.

6. Storage

- Store the valve dry and dust-free.
- If the valve is stored for more than 6 months the maintenance as described in point 5.2 has to be done before putting in operation.

7. Disposal

- The valve can be recycled.
 - The disposal applies to the valid environmental guidelines according to the location of the user and the local manufacturing conditions.
-

EU-Konformitätserklärung EU-Declaration of Conformity

Wir/We

MOLLET Füllstandtechnik GmbH

Industriepark RIO 103
D-74706 Osterburken
Tel. 06291 64400 Fax 06291 9846

erklären hiermit, dass die Geräte:

declare that the devices:

Silo-Ex-Implo-Ventil

Silo-Ex-Implo-Valve

Typ **SEI-250-B4**

Type **SEI-250-B4**

auf die sich diese Erklärung bezieht, den folgenden Normen
oder normativen Dokumenten entsprechen:

to which this declaration relates is in accordance with
the following standards or other normative documents:

ATEX-Richtlinie 2014/34/EU

ATEX directive 2014/34/EU

und

and

DIN EN ISO 80079-36:2016

DIN EN ISO 80079-36:2016

Die grundlegenden Sicherheits- und Gesundheitsanforderungen werden erfüllt gemäß den Bestimmungen der Richtlinien und durch Einhaltung der Normen.

The Essential Health and Safety Requirements are assured by compliance with the directive and observance of the normative documents.

Die Geräte sind mit folgenden Angaben gekennzeichnet:

The marking of the equipment includes the following:

CE Ex II 2D Ex h IIIB T 70° C Db

Prüfprotokollnummer

ATEX-PP-08-926X

Test report number

Osterburken, den 20.08.2021

Osterburken, August 20th 2021



Wolfgang Hageleit
Geschäftsführer / Managing director

Diese Erklärung darf nur unverändert
weiterverbreitet werden.

This declaration is only allowed to
hand out in unchanged form.